

Name: _____

Date: _____

BIOLOGY EXPERIMENT:

Class: _____

LAB #: _____

Identifying Laboratory Equipment

Introduction

Scientists use a variety of tools to explore the world around them. Tools are very important in the advancement of science. The type of tools scientists use depends on the problems they are trying to solve. A scientist may use something as simple as a metric ruler to measure the length of a leaf. At another time, the same scientist may use a complex computer to analyze large amounts of data concerning hundreds of leaves.

In this investigation, you will identify pieces of laboratory equipment likely to be found in a biology laboratory. You will also learn the function of each piece of laboratory equipment.

Aim

What are the names and functions of some of the pieces of laboratory equipment found in a typical biology laboratory?

Pre-Lab Discussion

Read the entire investigation. Then answer the following questions.

1. What kinds of measurements might you need to make in the laboratory?

2. What kinds of equipment would you need for these tasks?

3. Why are there several types of glassware marked for measuring?



4. How might glassware be used differently?







3. Which might you need to use a thermometer in the lab?

Safety 

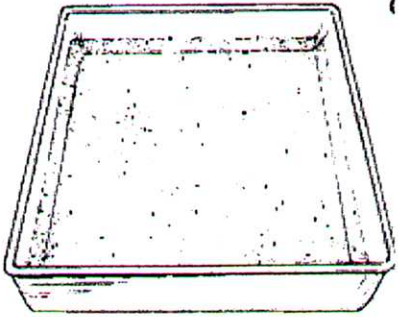
Handle all glassware carefully. Be careful when handling sharp instruments. Always handle the microscope with extreme care. You are responsible for its proper care and use. Use caution when handling glass slides, as they can break easily and cut you. Note all safety alert symbols next to the steps in the Procedure and review the meanings of each symbol by referring to Safety Symbols on page 8.

Procedure

-  1. Look at the drawings of the laboratory equipment in Figure 1. In the space provided, write the name of each piece of laboratory equipment.
-  2. Carefully inspect the different types of laboratory equipment that have been set out by your teacher. In the space provided write the name and function of each piece of laboratory equipment.

EQUIPMENT	NAME	USE(S)
 <p style="text-align: center;">A</p>		
 <p style="text-align: center;">B</p>		
 <p style="text-align: center;">C</p>		
 <p style="text-align: center;">D</p>		
 <p style="text-align: center;">E</p>		
 <p style="text-align: center;">F</p>		
 <p style="text-align: center;">G</p>		

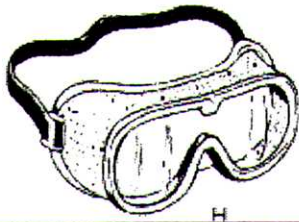

H

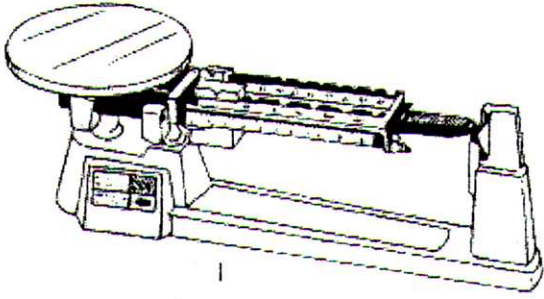

I

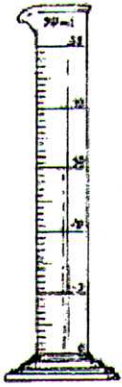

J



K



L

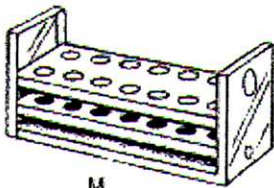

M

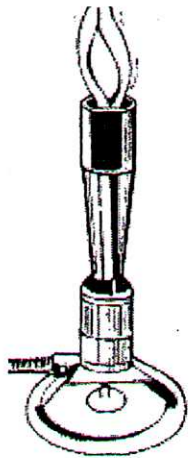

N



O

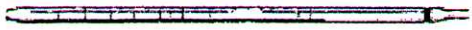

P

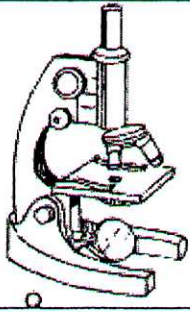

Q

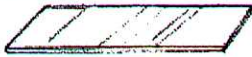

R

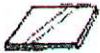

S



T



U

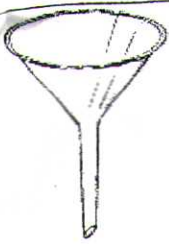

V

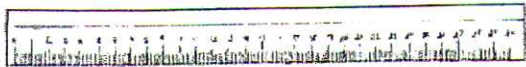

W

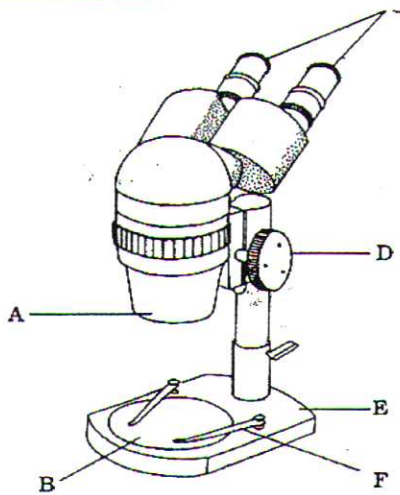
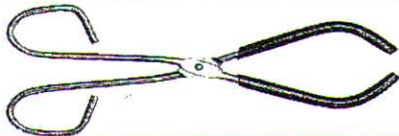
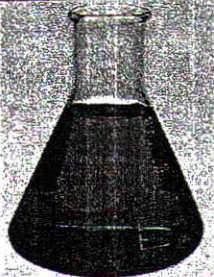
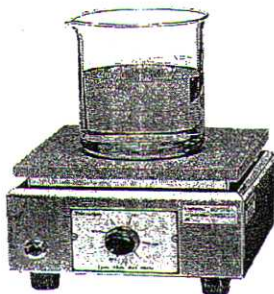

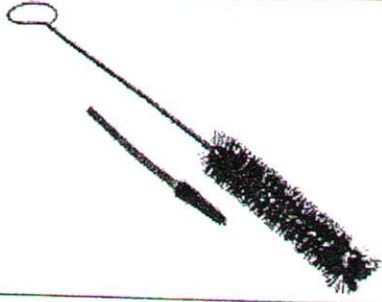

Analysis and Conclusions

1. **Classifying** Which laboratory tools (2) can be used to magnify small objects so they can be seen more easily?

2. **Classifying** Which laboratory tools (3) are useful when looking at the internal organs of an earthworm?

3. **Applying Concepts** What tool or tools would you use to make each of the following measurements?

a. amount of milk in a small glass

b. length of a sheet of paper

c. temperature of the water in a swimming pool

d. mass of a baseball

4. **Drawing Conclusions** How do laboratory tools improve the observations made by a scientist?